

PROSTOR SLOBODE

ANKETNI ARHITEKTONSKI KONKURS
BOB I SANKAŠKA STAZANA TREBEVIĆU

SPACE OF FREEDOM

COMPETITION FOR ARCHITECTURE IDEAS
BOB AND SLEDGE TRACK ON TREBEVIĆ MOUNTAIN



DANI ARHITEKTURE
DAYS OF ARCHITECTURE
SARAJEVO

Sarajevo, na mostu ili nad provalijom između zapada i istoka, zanimljivo je mjesto za prepoznavanje sve zatvorenije logike oba svijeta. Mjesto koje još nije do kraja iskontrolirano, u kojem su mogući i drugačiji scenariji. Prostor u kojem možemo zamisliti neke druge budućnosti. Grad koji čeka da iz prave potrebe izraste nova autentična kultura...

Dani arhitekture Sarajevo i ovogodišnji kurator Dinko Peračić pozivaju vas da ponudite svoja rješenja i ideje za jedinstven sarajevski "prostor slobode" - bob i sankasku stazu na Trebeviću.

Staza za bob i sankanje izgrađena je u okviru priprema za Zimske olimpijske igre koje su se 1984.g. održale u Sarajevu. Planirana je kao dio sportsko-rekreativnog parka na Trebeviću koji će i poslije igara privlačiti posjetitelje na planinu. Kompleks je u potpunosti izgrađen do septembra 1982 godine. Prof. Gorazd Bučar zajedno sa grupom arhitekata projektuje stazu u dužini od 1570m, odnosno od 1900m sa dvije rekreativne izlazne-zaustavne rampe. Staza se sastoji od pravih dionica i 13 krivina u obliku propisanih "figura", sa prosječnim uzdužnim padom staze od 10,2%, a najvećim od 15%.

Nakon Olimpijskih igara, staza je korištena za takmičenja u sklopu Svjetskog kupa. Naknadnom podjelom staze na tri dijela, koji se mogu neovisno koristiti, objekat je prilagođen i za potrebe svakodnevnog sankanja.

Sarajevo, on the bridge or above the chasm between the west and the east, is an interesting place to recognize the increasingly closed logic of both worlds. A place that has not yet been completely controlled, in which different scenarios are possible. A place where we can imagine some other future. A city waiting for a new authentic culture to be created out of a genuine need...

Days of Architecture Sarajevo and this year's curator Dinko Peračić invite you to offer your solutions and ideas for the unique Sarajevan "space of freedom", Bob and sledge track on Trebević mountain.

The bob and sledge track was built during the preparations for the Winter Olympics held in 1984. in Sarajevo. It was planned as part of the sports and recreational park on Trebević, which would also attract visitors to the mountain after the games. The complex was completely built until September 1982. Prof. Gorazd Bučar, together with a group of architects, designed a track in the length of 1570m, that is 1900m with two recreational exit-stop ramps. The track consists of straight sections and 13 curves in the form of prescribed "figures", with an average longitudinal slope of 10.2% and a maximum of 15%.

After the Olympic Games, the track was used for the World Cup. By subsequently dividing the track into three parts that could be used independently, the facility was adapted for the needs of everyday sledding.



FOTO: IVAN RAMADAN



FOTO: KENAN MUSLIC

U toku rata 90-tih godina staza se našla na prvoj liniji fronta. Staza je znatno oštećena i ostalo je samo betonsko korito. Rat je ostavio minska polja, razorene objekte i okolnu prirodu, te jedno novo značenje nekada popularne destinacije nadomak grada. Gotovo dvije decenije ovo područje imalo je reputaciju ničije zemlje, ekscesnog prostora izvan nadležnosti. Upravo u ovom kontekstu nastaju alternativni načini korištenja bob staz - najprije iscartavanje grafita. Danas je ona popularno mjesto šetanja, trčanja, fotografisanja, ekstremnih sportova kao down-hill biciklizma. Sve ovo stazu je učinilo neformalnim simbolom postapokaliptičnog stanja i popularnom slikom na društvenim mrežama.

Na ovaj način, cijeli ovaj prostor postepeno se vraćao u svakodnevni život grada. Ovaj povratak svoj vrhunac očekuje 6. aprila ove godine, na dan grada Sarajeva kada je planirano otvorenje trebevičke žičare koja povezuje centar grada sa neposrednom okolinom staze. Bob staza će se ponovo naći u srcu grada!

Da li možemo zamisliti novi život ove infrastrukture? Koji su novi scenariji aktiviranja ovog prostora?

Konkursnim radom treba predložiti zahvat u prostoru koji bob stazi i planini Trebević nudi novi identitet i nove oblike korištenja, uzimajući u obzir njegovu bogatu prošlost...

During wartime in 1990s, the track was located on the front-line. The track was significantly damaged and only the concrete trough is left. The war left behind minefields, destruction of objects and the surrounding nature and brought new meaning to the once popular destination near the city. For nearly two decades, this area have had the reputation of a no man's land, an excess space beyond any jurisdiction. It was in this context that alternative methods of use began to appear, the first being graffiti drawings. Today it is a popular place for walking, running, photography and extreme sports like down-hill cycling. All of this made the track an informal symbol of a post-apocalyptic state and a popular image on social networks.

Thus, the entire space gradually returned to the everyday life of the city. The peak of this comeback is expected on April 6th this year, on the day of the city of Sarajevo, when the opening of the Trebevic cableway that connects the city center with the immediate surroundings of the track is announced. The bob track will be in the heart of the city again!

Can we imagine the new life of this infrastructure? Which are new scenarios for activating this space?

Participants should propose spatial intervention, which will offer new identity and new forms of use, for bob and sledge track and mountain Trebevic, while taking into account their rich history...



FOTO: IVAN RAMADAN



FOTO: KENAN MUSLIC

POPREČNI PRESJEK B SANKAŠKE I BOB STAZE NA TREBEVIĆU
CROSS SECTION B - BOB AND SLEDGE TRACK ON TREBEVIĆ MOUNTAIN

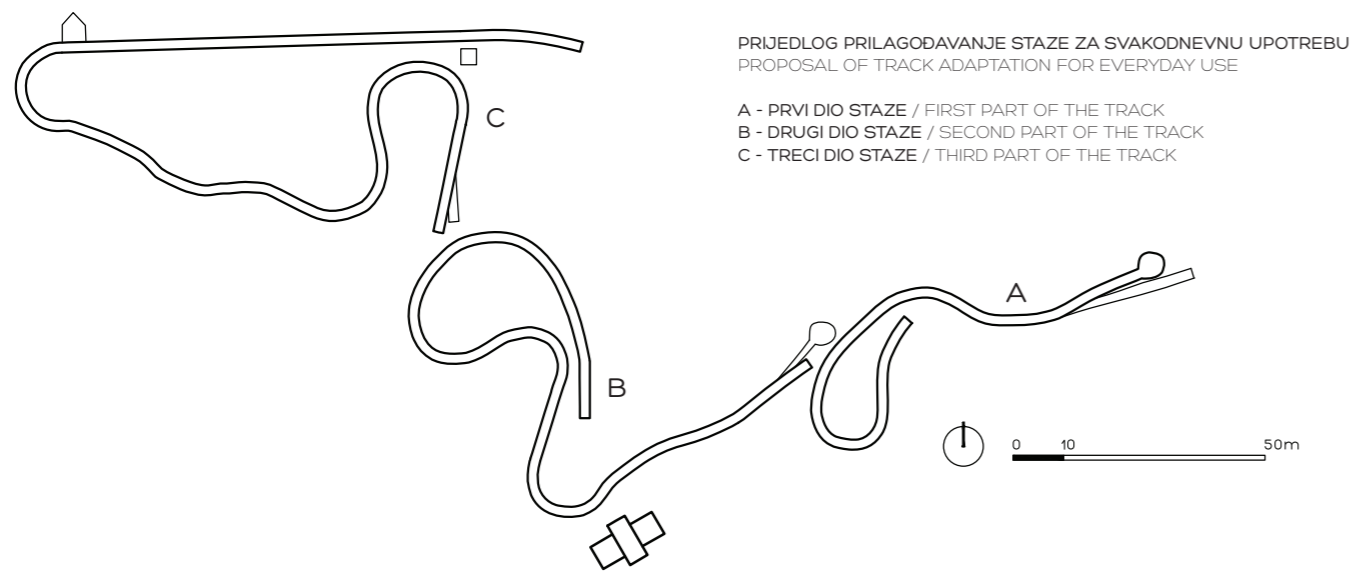
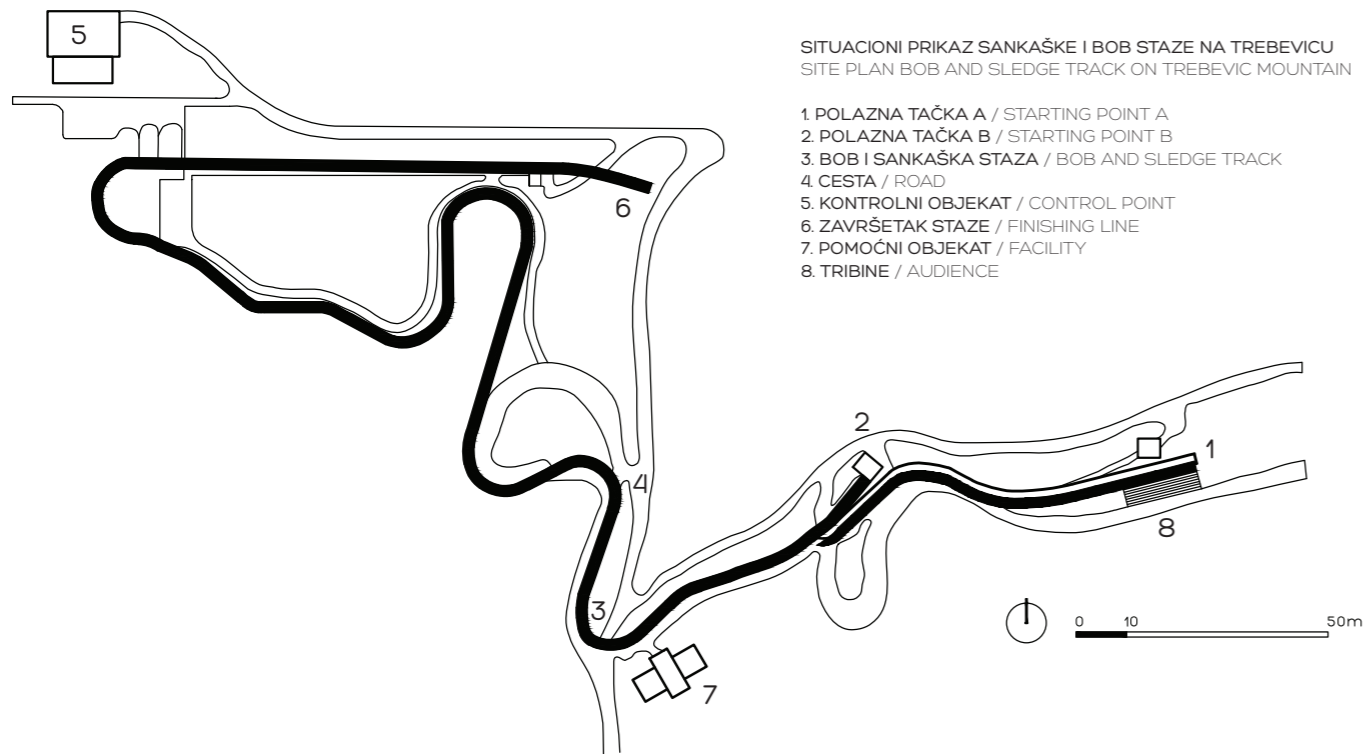
1. AB KORITO BOB STAZE / REINFORCED CONCRETE OF BOB TRACK
2. AB NOSAČ / REINFORCED CONCRETE CONSTRUCTION
3. ŽAŠTITNA OGRADA / PROTECTIVE FENCE
4. PRISTUPNA STAZA / ACCESS PATH
5. INSTALACIONI KANAL / INSTALLATION CHANNEL

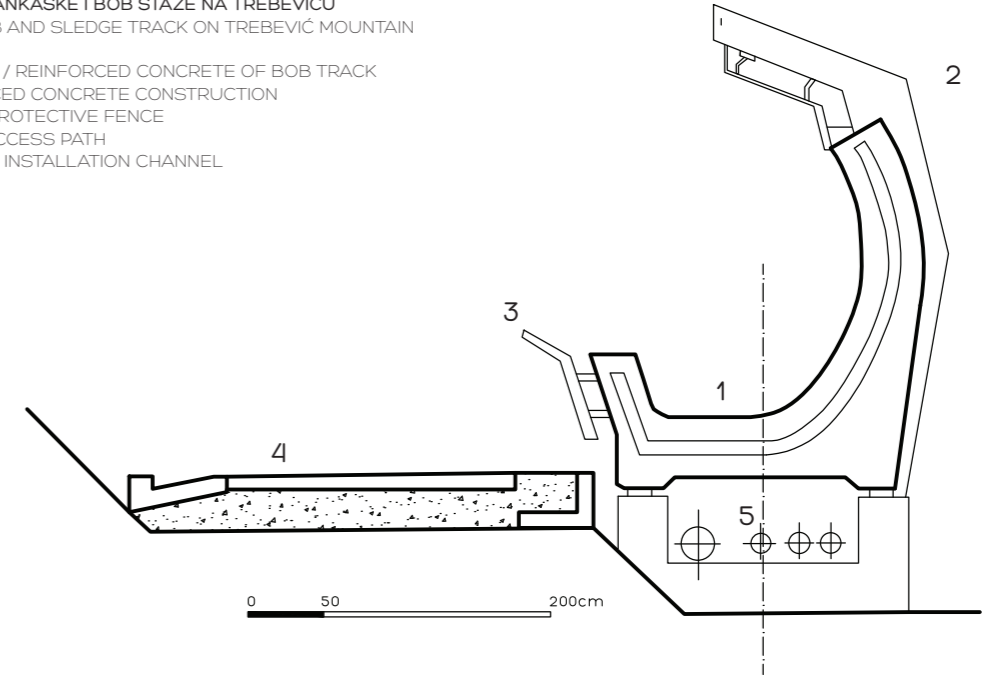

POPREČNI PRESJEK A SANKAŠKE I BOB STAZE NA TREBEVIĆU
CROSS SECTION A - BOB AND SLEDGE TRACK ON TREBEVIĆ MOUNTAIN

1. AB KORITO BOB STAZE / REINFORCED CONCRETE OF BOB TRACK
2. AB NOSAČ / REINFORCED CONCRETE CONSTRUCTION
3. ŽAŠTITNA OGRADA / PROTECTIVE FENCE
4. PRISTUPNA STAZA / ACCESS PATH
5. INSTALACIONI KANAL / INSTALLATION CHANNEL

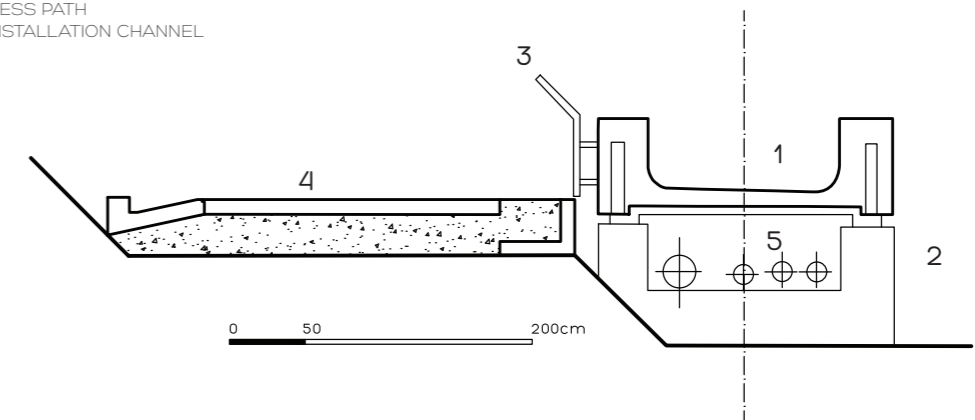

OBAVEZNI PROJEKTNI PRILOZI

- Naziv projekta i opis (do 1500 karaktera) .TXT
- Minimalno 3 grafička priloga u .JPG formatu 21x21cm 300dpi (fotomontaža, crteži, kolaži, dijagrami, skice...)
- Animirani .GIF 1000x1000px koji uključuje sve grafičke priloge
- Podaci o autorima (ime i prezime / autorski tim, grad/ država, e-mail, kratka biografija do 500 karaktera) .TXT

Važna napomena: grafički prilozi ne smiju sadržavati imena autora.

DATUMI I DOSTAVLJANJE RADOVA

Raspis konkursa: 26.02.2018.
Rok za dostavljanje radova: 15.04.2018. do 23.59h
Rezultati: 25.04.2018.

Projekti se dostavljaju na e-mail:
info@daniarhitekture.ba

PRAVO SUDJELOVANJA

Konkurs je međunarodni, anketni, anonimni i jednostepeni. Pravo prijave imaju studenti i mladi profesionalci do 35 godina starosti. Arhitekti, dizajneri, multimedijalni umjetnici, fotografi i svi drugi su pozvani na učešće.

PODLOGE I PITANJA

Podloge za konkurs možete preuzeti na linkovima:
http://www.daniarhitekture.ba/DA2018_competition.zip

Pitanja vezana za raspis konkursa možete postaviti na email:
info@daniarhitekture.ba

JEZIK KONKURSA

Učesnici konkursa svoje radove mogu dostaviti na : bosanskom, hrvatskom, srpskom i engleskom jeziku.

ŽIRI

Dinko Peračić (Hrvatska)
Marija Simović (Studio Simović, Srbija)
Kenan Vatrenjak (Filter arhitektura, BiH)
Katarina Bošnjak (Lift - prostorne inicijative, BiH)

NAGRADE

Svi pristigli radovi bit će objavljeni na web stranici Dana arhitekture i društvenim mrežama, te prikazani na izložbi u programu Dana arhitekture 2018.

Stručni žiri će odabrati 7 najboljih radova, čiji će autori biti pozvani da učestvuju i prezentuju radove na Danima arhitekture 2018. Svim učesnicima će biti obezbijeđen je smještaj Sarajevu i ulaznice za sve događaje u okviru Dana arhitekture 2018.

Nakon prezentacija, stručni žiri i publika će odabrati najbolji rad za koji je osigurana novčana nagrada 300 EUR.

Odabrani radovi će potencijalno biti prezentirani u javnim medijima i gradskoj upravi.

ORGANIZATOR

Dani arhitekture Sarajevo <http://www.daniarhitekture.ba>
LIFT - prostorne inicijative <http://l-i-f-t.org>

MEDIJSKI PARTNERI

AABH <http://www.aabh.ba>
Designed <http://www.designed.rs>
Časopis Tristotrojka <http://www.facebook.com/tristotrojka>
Istraživački centar za prostor <http://icprostor.wordpress.com>

FOTOGRAFIJE

Ivan Ramadan, Kenan Muslić,
Irhana Šehović

PROJECT PROPOSAL REQUIREMENTS

- Project title and description (up to 1500 characters) .TXT
- Minimum 3 graphic materials .JPG 21x21cm 300dpi (photomontage, drawings, collages, diagrams, sketches...)
- Animated .GIF 1000x1000px with all graphic materials
- Author information (name and surname / team name, city/ country, e-mail, short biography up to 500 characters)

Important note: graphics must not contain author's name.

DATES AND SUBMISSION

Call for competition: February 26, 2018
Deadline for submission of works: April 15, 2018 23:59h
Results: April 25, 2018

Entries should be submitted via:
info@daniarhitekture.ba

PARTICIPATION

The competition is international, idea and single-stage. Open to students and young professionals under the age of 35. Architects, designers, multimedia artists, photographers and others are welcome to apply.

COMPETITION MATERIALS AND QUESTIONS

The competition materials download links:
http://www.daniarhitekture.ba/DA2018_competition.zip

You can ask questions regarding the competition call via:
info@daniarhitekture.ba

COMPETITION LANGUAGE

Participants of the competition can submit their works in: Bosnian, Croatian, Serbian and English language.

JURY

Dinko Peračić (Croatia)
Marija Simović (Studio Simović, Serbia)
Kenan Vatrenjak (Filter arhitektura, B&H)
Katarina Bošnjak (Lift - spatial initiatives, B&H)

AWARDS

All submitted projects will be published at Days of Architecture website and social media, and exhibited within programme of Days of Architecture 2018.

The expert jury will select 7 best projects. Selected authors will be invited to present their projects at Days of Architecture 2018 and will be provided with accommodation in Sarajevo and tickets for all events within the festival.

After presentations, the expert jury and audience will select the best project for the award 300 EUR.

Selected projects will be potentially presented in public media and to the municipality.

ORGANIZER

Days of Architecture Sarajevo <http://www.daniarhitekture.ba>
LIFT - spatial initiatives <http://l-i-f-t.org>

MEDIA PARTNERS

AABH <http://www.aabh.ba>
Designed <http://www.designed.rs>
Časopis Tristotrojka <http://www.facebook.com/tristotrojka>
Istraživački centar za prostor <http://icprostor.wordpress.com>

PHOTOS

Ivan Ramadan, Kenan Muslić,
Irhana Šehović



DANI ARHITEKTURE
DAYS OF ARCHITECTURE
SARAJEVO

FOTO: IVAN RAMADAN

© 2018 DAYS OF ARCHITECTURE / LIFT - SPATIAL INITIATIVES